

1:1 scale



57mm

INTRODUCTION TO ZIPLINE

The Zipline is a self-contained pre-wired trunking and LED lighting system offering unparalleled flexibility in terms of lighting layout and scheme design. The Zipline combines architectural impact, longevity and supreme efficiency (192.1 LL/CW) providing the lighting designer with the perfect lighting solution for many building-wide applications. With five luminaire power options, broad, narrow and double asymmetric light distributions and a variety of accessories the Zipline is a truly versatile suspended or surface mounted lighting system.



EDUCATION

MANUFACTURING

WAREHOUSE



192.1

LUMINAIRE LUMENS
PER CIRCUIT WATT



RETAIL

GALLERY

AND MANY MORE

ZIPLINE

ZIPLINE SYSTEM

The Zipline system is made up of four main elements. An extruded aluminium trunking provides the backbone and contains wiring with sockets located at 750mm intervals for connecting a range of modules. The modules can be any combination of luminaire, emergency luminaire, spotlight and passive infra-red detector. Where modules are not required an extruded PVC lid is used to fill in blank spaces. Finally, a small amount of components complete a fast and simple installation.

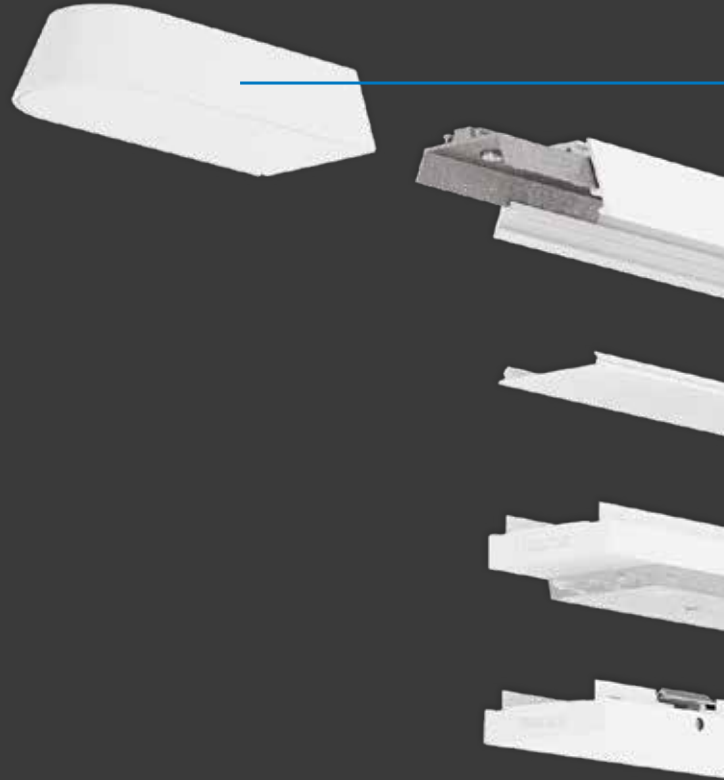

A

TRUNKING

Pre-wired lengths up to 4.5m long are joined together to form the required run. The factory installed wiring looms (7-core 1.5mm² PVC as standard) are simply plugged together and provide electrical connection sockets at 750mm intervals. Luminaire modules may be installed continuously, or with either 750mm or 1500mm spaces between them. Elbow, tee and crossover joints are used to continue the trunking run in a variety of directions.

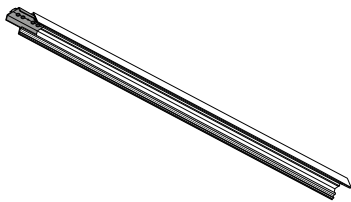

Available lengths



Maximum total distance in one run depends upon circuit design. See advice on page 7

Joints

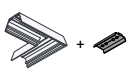

Elbow Joint

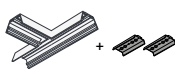

Tee Joint

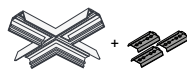

Crossover Joint

B

LUMINAIRES

All luminaire modules are based on a standard length of 1500mm. Options include narrow, broad and double asymmetric distributions, 5 output levels, conventionally switched and dimmable circuit types or with integral Smart controls.

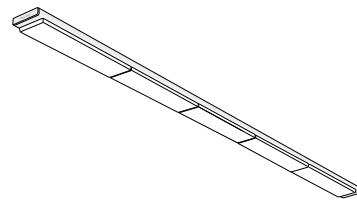

Distributions

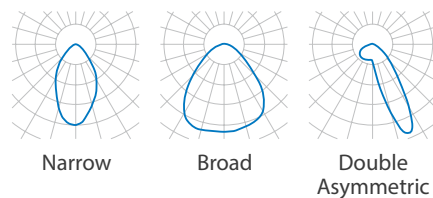

Power Levels

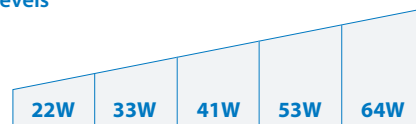

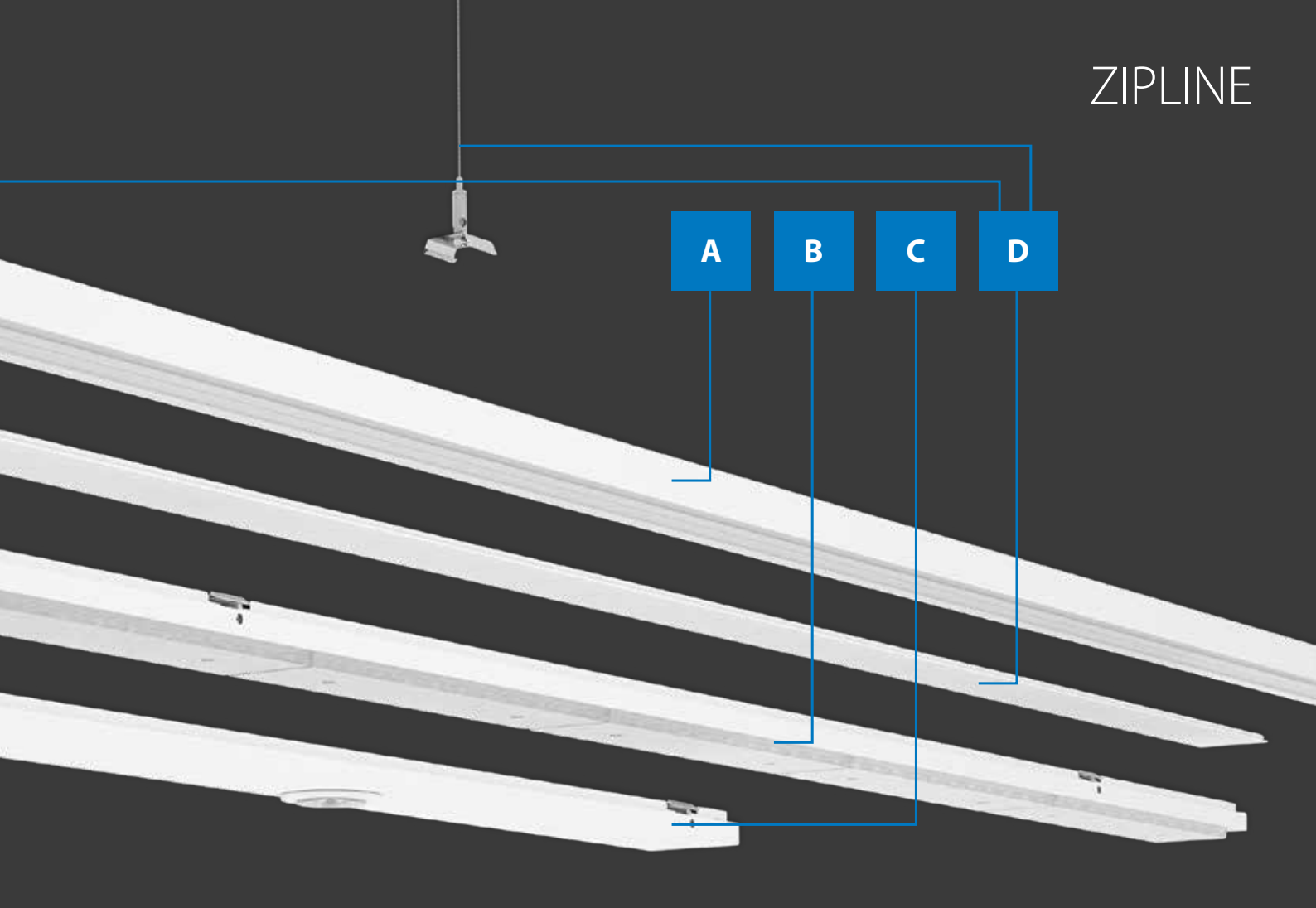

C
MODULE OPTIONS

Options include a PIR module for automatic control (if required when Smart luminaire modules are not used), emergency lighting modules, and spotlight modules. All modules are 750mm long.

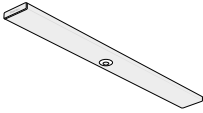

Lighting Controls
PIR Module

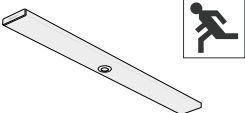

Emergency Lighting Module
SmartScan Option
Area and corridor versions available

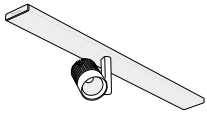

Display Lighting
Single Spotlight Module

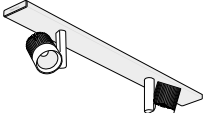

Display Lighting
Twin Spotlight Module

D
FINISHING COMPONENTS

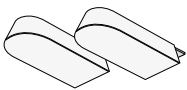

End Kit
1 kit required per row, includes live end (mains feed) and dead end



Snap-in Infill Lid
1500mm lengths



Wire Suspension Kit*



Surface Mounting Kit*

*see the mounting point spacing table on [page 9](#) for required quantities of Wire Suspension or Surface Mounting kits

ZIPLINE INTEGRATED LIGHTING CONTROLS

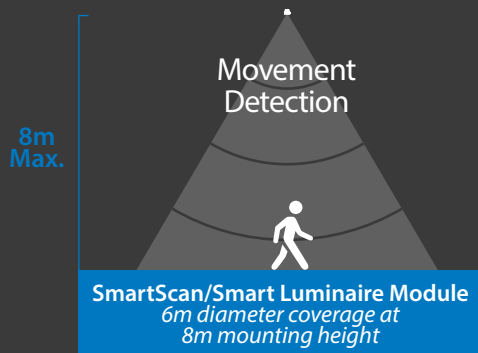

Option 1

Smart Luminaire Modules (1500mm)

Smart

A discrete sensor integral to the luminaire monitors ambient light and presence, controlling output to the correct level and ensuring that the area is only illuminated when occupied.

Motionline

Individual Thorlux Smart luminaires are automatically linked, via the trunking wiring, into a linear group using 'Motionline'. Individual runs of trunking can be linked by connecting between live end connectors see page 7.

NOTE: Minimum 750mm space required between Smart luminaire modules

For full details of the Thorlux Smart System including movement detection and Motionline see www.thorlux.com/controls

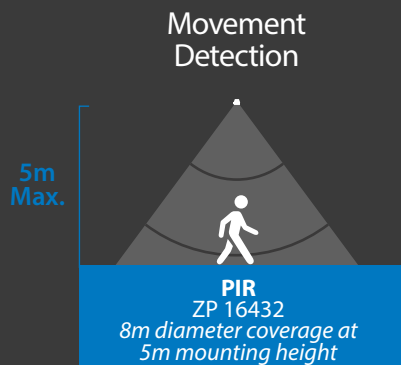

Option 2

PIR Module (750mm)

A cost effective lighting control solution, without the luxury features of a full Smart System, PIR modules can be selected and simply plugged in, to provide passive infra-red detection for each connected run. As many PIR modules as required for suitable detection coverage can be fitted and the entire run will be switched as a whole group.

ZIPLINE EMERGENCY LIGHTING

Option 2

Emergency LED Module (750mm)

- Area or corridor distributions
- Can be positioned between luminaire modules for best effect
- Superb photometric performance
- SmartScan option with integral Firefly Plus or Firefly

Option 1

Emergency Version of Luminaire (1500mm)

Standard luminaire modules are available with an Emergency option, shown as EZP in the ordering process

Zipline offers the choice of either emergency versions of the luminaire or dedicated modules which utilise a reliable, unobtrusive SmartScan LED downlight. The superb optical performance of the area and corridor lens minimises the number of modules required.

For full details of Thorlux Emergency Lighting Systems see www.thorlux.com/controls

ZIPLINE DISPLAY LIGHTING

Adjustable Spotlights

Adjustable single or twin LED spotlights ideal for reception and showroom areas.

- One or two adjustable spotlights in one 750mm module
- Extruded aluminium heat sink finished in black for passive thermal management with no cooling fan
- Adjustable spotlight with $\pm 95^\circ$ tilt, 360° degree rotation
- 30° beam angle

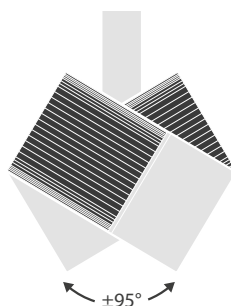

Single Option

1x 24W Adjustable Spotlight

Twin Option

2x 24W Adjustable Spotlight

ZIPLINE



SIMPLE WIRING

The wiring loom provides connection sockets at 750mm intervals. When trunking sections are joined, the wiring looms are simply plugged together.

Live End Connector

Up to 7 cores may be wired into the Live End connector, depending upon the project requirements*

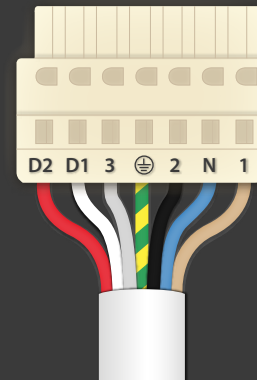

Function	Core	
D2	Motionline (+) or DALI	Red
D1	Motionline (-) or DALI	White
3	Switched live: Spot/Track Modules	Grey
⊕	Earth	Green & Yellow
2	Perm/Em/SmartScan	Black
N	Neutral	Blue
1	Switched live: Luminaire Modules	Brown

* The 7 cables used within the Zipline trunking are 1.5mm² CSA H07V2 tri-rated PVC insulated 400V, 85°C rated. Voltage drop 29mV/A/m maximum current rating for the system and connectors is 8A. Maximum distance depends upon design parameters such as circuit fusing, earth loop impedance and local regulations. All components within the system will operate at a voltage range of 220V-240V +/- 10%. Each module section has an internally mounted, replaceable 3A fuse.

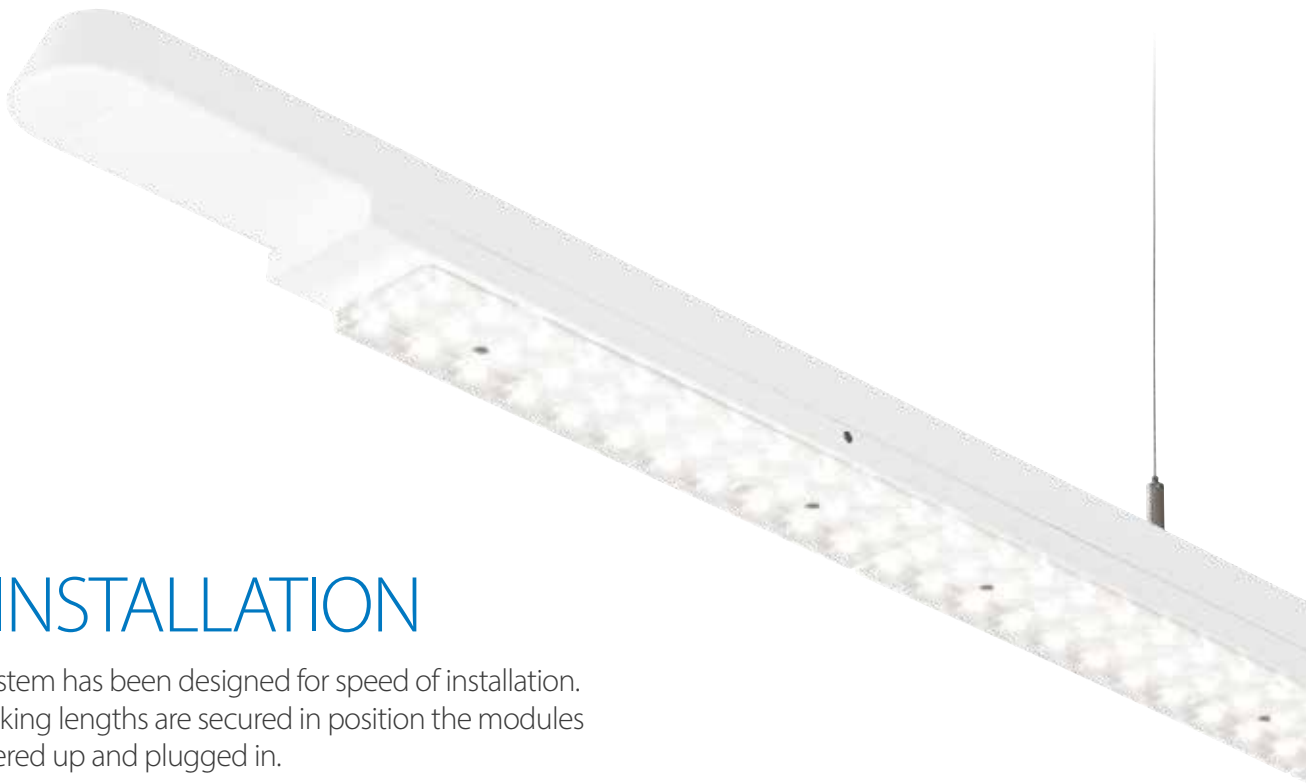

FAST INSTALLATION

The Zipline system has been designed for speed of installation. Once the trunking lengths are secured in position the modules are simply offered up and plugged in.

START

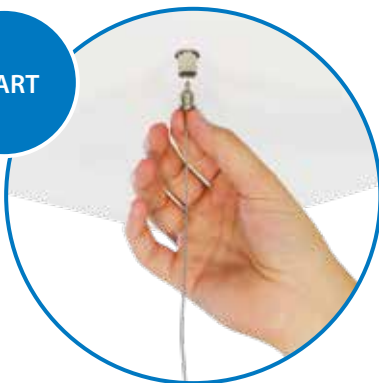

1. Fix suspension wires*

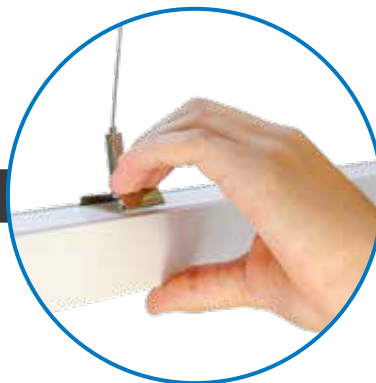

2. Clip trunking to suspension



3. Join trunking lengths together



4. Fix end kits and wire supply**

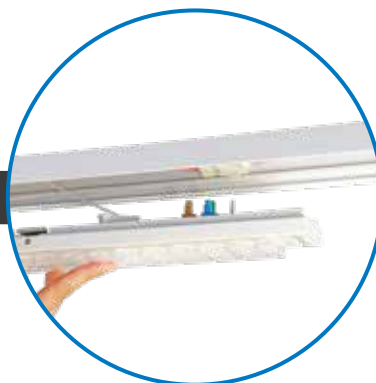

5. Clip modules onto trunking



COMPLETE

* Maximum spacing of 2500mm between suspension fixings. Maximum weight at each suspension point assuming fully loaded assembled system = 5kg

** For full wiring details see the Zipline installation leaflet

ZIPLINE

DIMENSIONS

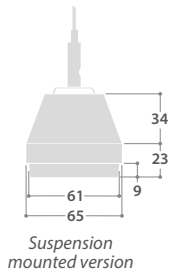

Suspension mounted version

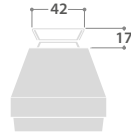

Surface mounted version

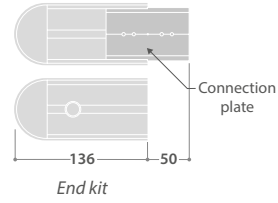

End kit

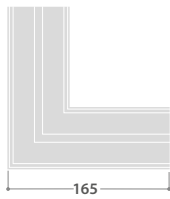

Elbow Joint

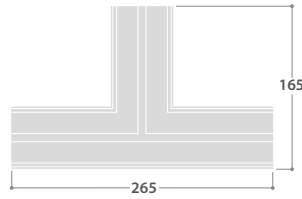

Tee Joint

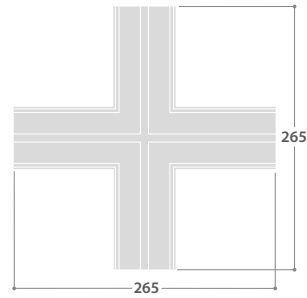

Crossover Joint

MOUNTING POINT SPACING TABLE

Based on a maximum spacing of 2.5m between points. The first and last points are 500mm from each end. These apply to both suspended and surface mounting.

TOTAL LENGTH	QUANTITY	SPACING
4.5m	3	1.750m
6.0m	3	2.500m
7.5m	4	2.167m
9.0m	5	2.000m
10.5m	5	2.375m
12.0m	6	2.200m
13.5m	6	2.500m
15.0m	7	2.334m
16.5m	8	2.215m
18.0m	8	2.429m
19.5m	9	2.313m
21.0m	9	2.500m
22.5m	10	2.389m
24.0m	11	2.300m
25.5m	11	2.450m
27.0m	12	2.364m
28.5m	12	2.500m
30.0m	13	2.417m
31.5m	14	2.347m
33.0m	14	2.462m
34.5m	15	2.393m

PHOTOMETRIC GUIDE

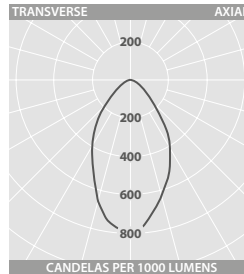

NARROW

Luminaire Lumen Output
 22W = 4470lm
 33W = 6655lm
 41W = 7530lm
 53W = 9570lm
 64W = 10975lm

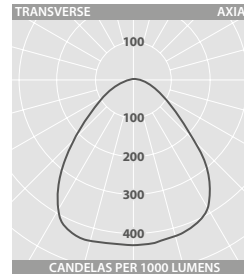

BROAD

Luminaire Lumen Output
 22W = 4400lm
 33W = 6530lm
 41W = 7395lm
 53W = 9405lm
 64W = 10780lm

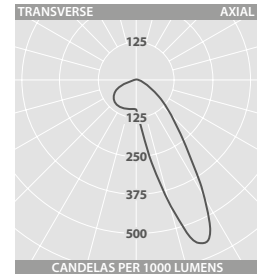

DOUBLE ASYMMETRIC

Luminaire Lumen Output
 22W = 4525lm
 33W = 6725lm
 41W = 7640lm
 53W = 9695lm
 64W = 11060lm

CONTINUOUS LED LIGHTING SYSTEM



SPECIFICATION

- Extruded aluminium trunking finished full polyester non-yellowing satin white (RAL 9016)
- Pre-installed wiring loom, module sockets at 750mm intervals
- Plug and socket connections between trunking joints
- Luminaire modules have three lens options
- SmartScan wireless technology removes the need for control cabling. Ideal for retro-fit
- Modules click fit using stainless steel spring (requires a standard screwdriver to release)

LED CHARACTERISTICS

CRI	80+
COLOUR TEMPERATURE	4000K
RATED LIFE (HOURS)	100K - L70/B10
PROTECTION	LUX GUARD
DRIVER EFFICIENCY	>88%
REPLACEABLE	YES
POWER FACTOR	>0.9
LL/CW	192.1

For LED characteristics explanation see www.thorlux.com/led-guide

Luminaire Module SmartScan Configurations



Find out more at www.thorlux.com/smartsan

Emergency Module SmartScan Configurations



Find out more at www.thorlux.com/smartsan

1 TRUNKING RANGE

DESCRIPTION	CAT. No.	APPROX. kg
1.5m	ZP 16412	1.6
3.0m	ZP 16411	3.2
4.5m	ZP 16410	4.8
Elbow joint	ZP 16556	0.2
Tee joint	ZP 16557	0.3
Crossover joint	ZP 16558	0.4

2 LUMINAIRE MODULE RANGE

	NOMINAL SIZE (mm)	LED	NARROW	BROAD	DOUBLE ASYMMETRIC	APPROX. kg	CIRCUIT
SMART	1500	22W	ZP 16416	ZP 16420	ZP 16561	2.5	D/SS
		33W	ZP 16417	ZP 16421	ZP 16562	2.5	D/SS
		41W	ZP 16418	ZP 16422	ZP 16563	2.5	D/SS
		53W	ZP 16419	ZP 16423	ZP 16564	2.5	D/SS
		64W	ZP 16602	ZP 16600	ZP 16604	2.5	D/SS
STANDARD	1500	22W	ZP 16424	ZP 16428	ZP 16565	2.4	L/A
		33W	ZP 16425	ZP 16429	ZP 16566	2.4	L/A
		41W	ZP 16426	ZP 16430	ZP 16567	2.4	L/A
		53W	ZP 16427	ZP 16431	ZP 16568	2.4	L/A
		64W	ZP 16603	ZP 16601	ZP 16605	2.4	L/A

CIRCUIT TYPE - suffix catalogue number with:

SMART D - Smart / SS - SmartScan

STANDARD L - non-dimming (LED) / A - dimming (DALI) e.g. ZP 16416SS etc.

EMERGENCY VERSION - prefix catalogue number with:

EZP - Emergency (Not available when selecting the 'SS' suffix)

WZP - SmartScan (Only available when selecting the 'SS' suffix)

e.g. **WZP 16416SS** etc.

Add 0.3kg to weights listed.

3 MODULE OPTIONS

DESCRIPTION	CAT. No.	APPROX. kg
Presence detector module	ZP 16432	0.9
SmartScan Firefly Plus Emergency (<i>standard downlighter</i>)	WZP 19627	1.3
SmartScan Firefly Plus Emergency (<i>area downlighter</i>)	WZP 19628	1.3
SmartScan Firefly Emergency (<i>area downlighter</i>)	WZP 16435	1.3
SmartScan Firefly Emergency (<i>corridor downlighter</i>)	WZP 16436	1.3
1 x 24W spotlight module (30° beam angle)	ZP 16559	1.6
2 x 24W spotlight module (30° beam angle)	ZP 16560	2.3

4 FINISHING COMPONENTS

DESCRIPTION	CAT. No.	APPROX. kg
Trunking snap-in infill lid (<i>nominal 1.5m lengths to be cut as required</i>)	ZP 16413	0.30
Trunking end kit (<i>1 kit required per row, includes live end and dead end</i>)	ZP 16414	0.35
Wire suspension kit* (<i>3m length, 1 mounting point per kit</i>)	ZP 16415	0.05
Surface mounting kit* (<i>1 mounting point per kit</i>)	ZP 16689	0.04

*see the mounting point spacing table for required quantities on page 9