



COMBOSEAL

HIGH PERFORMANCE SEALED INDUSTRIAL LUMINAIRES



COMBOSEAL & COMBOSEAL PLUS

Introducing the Comboseal range of low profile, high efficiency, IP66 circular LED luminaires for high and low bay applications, designed to be used as direct replacements for traditional single point suspended discharge luminaires up to 400W.



COMBOSEAL



COMBOSEAL PLUS



COMBOSEAL

The Comboseal is available in 65W, 98W and 137W power ratings, with Smart versions suitable for use up to 8m.

The strong high pressure die-cast aluminium body and polycarbonate cover make the Comboseal a tough impact resistant luminaire.

Designed to hang from a single suspension point, the balanced circular body is a suitable replacement for traditional discharge luminaires. Integral Smart controls and optional SmartScan wireless connectivity allow the installation of energy saving luminaires without the need for additional cabling.

The Thorlux designed PCBs are capable of producing over 20,000 lumens of white light, with colour rendition greater than 80 CRI.

COMBOSEAL PLUS

The Comboseal Plus is available in 171W, 251W and 326W power ratings with broad or narrow distribution, Smart versions suitable for mounting up to 18m.

The sleek aluminium construction paired with toughened glass cover make the Comboseal Plus ideal for use in dust and moisture laden environments and areas where chemicals are in use. For further details contact the Thorlux Technical department.

High efficiency control gear and medium power LEDs provide a total system life of 100,000 hours, even in versions suitable for operating in ambient temperatures up to 55°C.

The Thorlux designed PCBs are capable of producing over 44,000 lumens of white light, with colour rendition greater than 80 CRI. Narrow distribution versions have a dedicated lens for each of the 576 LEDs ensuring the most efficient distribution of light. At high mounting heights excellent optical performance can make significant improvements to illumination levels and uniformity providing long term energy savings not apparent from headline luminaire lumen output figures alone.



TAKE A LOOK INSIDE COMBOSEAL PLUS

1 SMART SENSOR

High level Smart Sensor optimised for presence detection up to 18m combined with daylight linking for energy savings which often exceed 70%. Wireless SmartScan versions remove the need for control cabling (see page 14).

2 CONTROL GEAR ENCLOSURE

Strong high pressure die-cast aluminium casting with integrated heat sink maximises heat dissipation from the control gear in high temperature applications, finished full polyester powder coat silver (RAL9006).

3 COVER CLAMPS

Strong high pressure die-cast aluminium castings provide uniform compression of the sealing gasket for excellent IP66 seal, finished full polyester powder coat silver (RAL9006).

4 SILICONE GASKETS

Long life thermally stable silicone gaskets maintain the IP rating for the life of the luminaire.

5 4MM THICK COVER

4mm thick toughened/safety glass cover has excellent chemical resistance and will not deteriorate in atmospheres that are harmful to plastics. For further details contact the Thorlux Technical department.

6 LED LENSES (NARROW VERSIONS)

Custom made acrylic lenses. A dedicated lens for each LED ensures the most efficient distribution of light.

7 LED PCBs

Four replaceable medium power LED PCBs with Thorlux patented LUX GUARD current sharing technology (see page 12).

8 CONTROL GEAR

Fully replaceable control gear. All electronic components have the same rated life as the LEDs.

9 DIE-CAST ALUMINIUM BODY

Strong high pressure die-cast aluminium top casting with smooth outer surface and internal fins to dissipate heat. Finished full polyester powder coat silver (RAL9006).

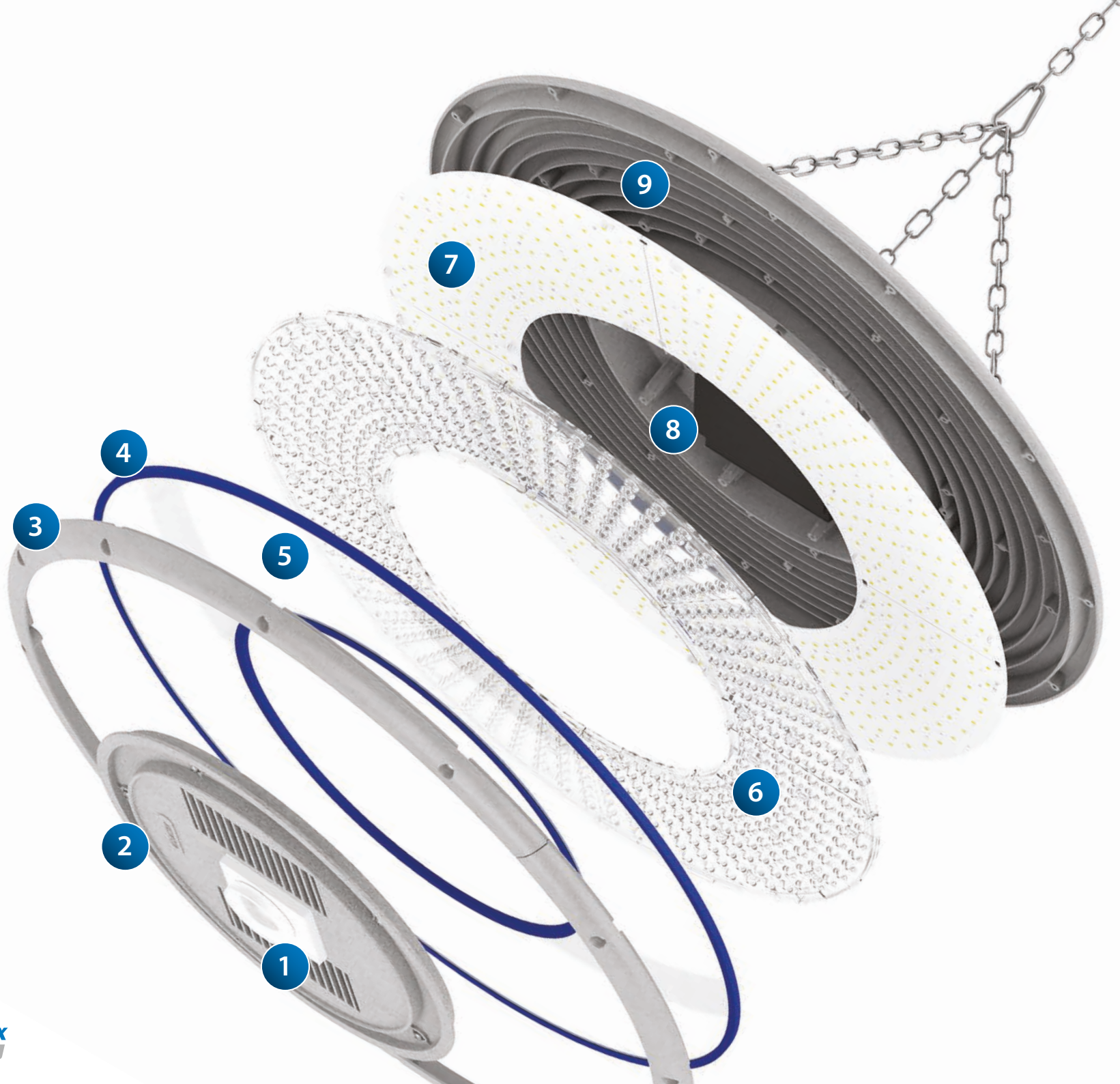

DESIGNED TO PERFORM IN HARSH ENVIRONMENTS



COMBOSEAL & COMBOSEAL PLUS PERFECTLY BALANCED

A balanced circular design allows for single point chain suspension.



COMBOSEAL & COMBOSEAL PLUS NO DUST TRAPS

Designed with smooth surfaces, the curved profile eliminates accumulation of dirt and 'ponding' of fluids.



COMBOSEAL PLUS A LENS FOR EVERY LED

Narrow distribution versions feature a dedicated lens for each LED to focus the light, providing supremely efficient optical performance at higher mounting heights.



COMBOSEAL PLUS CHEMICALLY RESISTANT

Full polyester powder coated aluminium body with smooth, sloped back and glass cover make Comboseal Plus ideal for use in areas where corrosive chemicals are used. For further details contact the Thorlux Technical department.

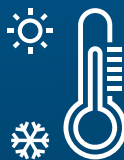

COMBOSEAL & COMBOSEAL PLUS FROM -40°C to +65°C

High specification control gear coupled with thermally optimised PCBs ensure efficient function of the luminaire in ambient temperatures from -40°C to +65°C (see pages 17 & 19).



HID

VS



COMBOSEAL RANGE

THE IDEAL LUMINAIRE WHEN EFFICIENCY IS KEY

100,000 hour LED life reduces maintenance costs. Improved lumen depreciation compared to traditional discharge lamps.

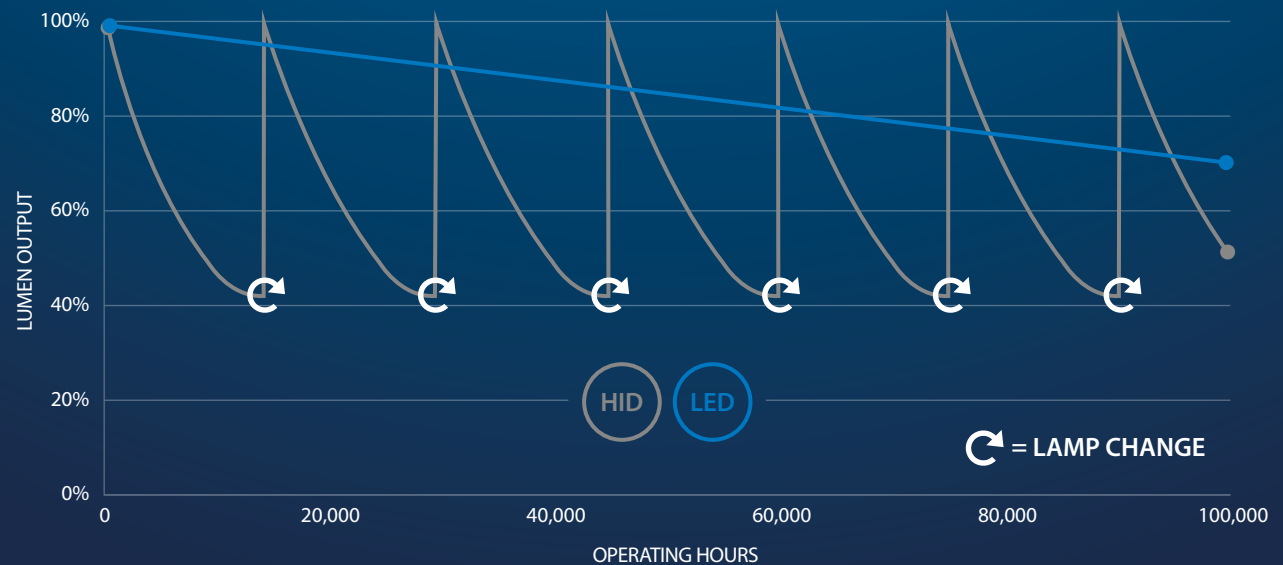

RATED LAMP LIFE



HOT RE-STRIKE TIME

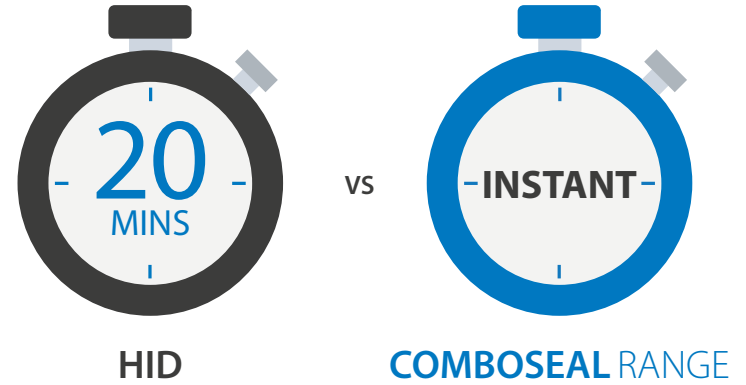

LAMP CHANGES OVER 100,000 HOURS

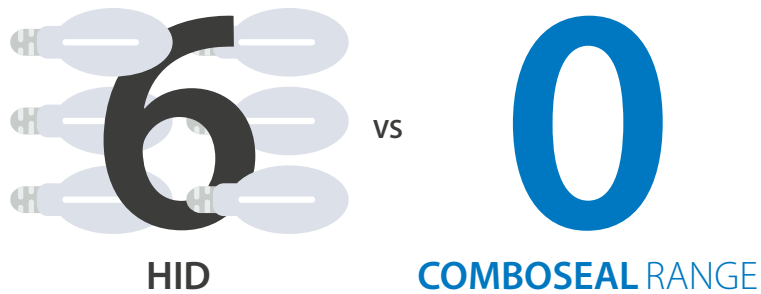

QUALITY OF LIGHT

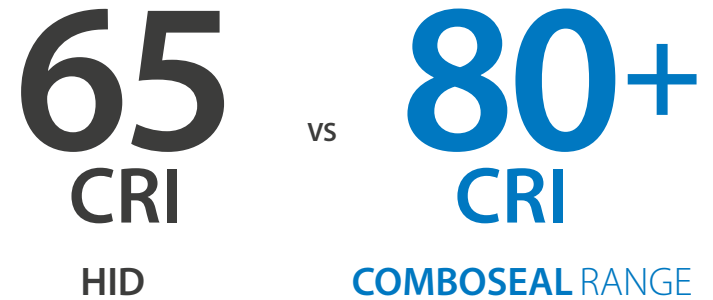

★ PATENTED ★

LUX
GUARD

LED SYSTEM PROTECTION

LEDs are a very efficient light source and are resilient to many conditions that can be detrimental to the lifetime of traditional lamps.

For example, LEDs are largely unaffected by frequent switching, shock or vibration. However, LEDs or their solder joints can infrequently fail. In such circumstances it would be inconvenient if the failure caused significant loss of light, or if the luminaire extinguished completely.

In many luminaires LEDs are linked in series whereby a current flows through each LED in turn. Should an LED or solder joint fail, a whole row of LEDs, or in fact all LEDs may extinguish. Thorlux has designed specific protective measures to prevent such a condition.

LUX GUARD by Thorlux, is a patented current sharing PCB and circuit design philosophy. If an LED fails then its current is shared via neighbouring circuits, with each LED's brightness increasing slightly to compensate. **LUX GUARD** ensures that a luminaire continues to provide its designed lumen performance, even in the case of nuisance LED failures, and reduces the maintenance costs of a project.

PARALLEL

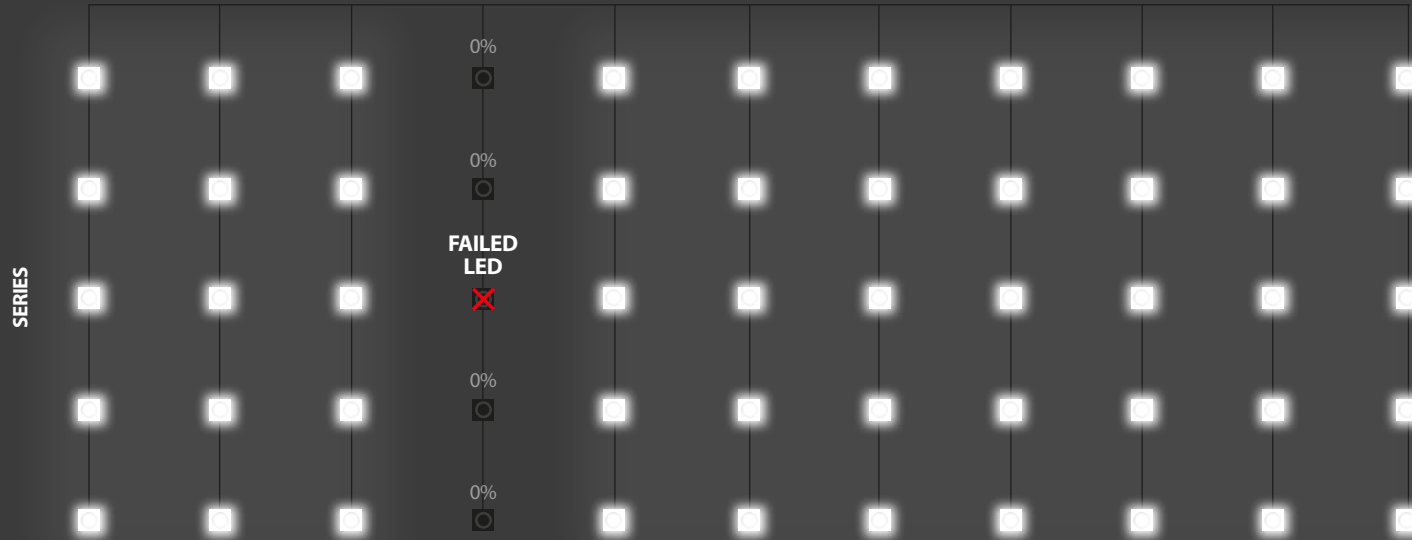

CONVENTIONAL
CIRCUIT

5 IN SERIES 11 IN PARALLEL

91% OUTPUT

PARALLEL



5 IN SERIES 11 IN PARALLEL

100% OUTPUT



SMART ENERGY SAVING CONTROLS

The Thorlux Smart System exploits the latest 'Digital Technology' to provide a simple, effective method of lighting control which minimises energy consumption whilst retaining high levels of user comfort.

A discrete sensor integral to the luminaire monitors ambient light and presence, controlling output to the correct level, and ensuring that the area is only illuminated when occupied.

Individual Thorlux Smart luminaires may be linked using a 'Motionline' two wire low voltage bus allowing luminaires to communicate within a group. Upgrading to SmartScan provides the option of full wireless Motionline control between Smart luminaires eliminating the need for additional cabling.

Savings by the installation of automatic lighting control systems often exceed 70%.

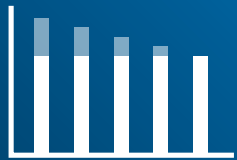

MAINTAINED ILLUMINANCE

Smart luminaires maintain the desired lighting level throughout the maintenance cycle by automatically increasing LED output as the light source ages, avoiding over lighting new installations.



DAYLIGHT DIMMING

When daylight enters an area the sensors will take this light into account and gradually dim the LEDs, saving energy whilst maintaining the required light level.



MOVEMENT DETECTION

Presence sensors in all luminaires ensure excellent detection coverage, so that Smart luminaires switch on when movement is detected and stay on whilst the room is being used.

FULL STATUS MONITORING OF YOUR HIGH BAY LUMINAIRE FROM THE GROUND

The functional status and energy performance of SmartScan luminaires can be monitored from anywhere via the SmartScan website (SmartScan Gateway required), or from the ground using the SmartScan Programmer.

The website provides an easy to read visual reference highlighting the following:

- Control gear status monitoring
- Light source functionality
- Thermal performance (the luminaire is operating within correct temperature limits)
- Average energy used by the luminaire
- Total hours powered
- Full energy performance monitoring



www.thorlux.com/smartsan

COMBOSEAL



SMART
VERSIONS
UP TO
8m

UP TO
20,000
LUMENS

DIMENSIONS

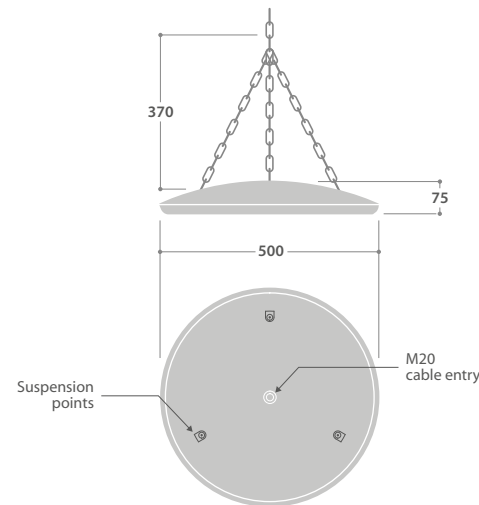

ACCESSORIES

DESCRIPTION	CAT. No.
Surface mount bracket	CS 18486

PHOTOMETRIC GUIDE

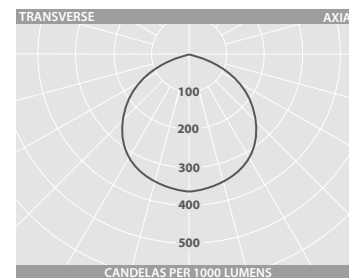

Luminaire Lumen Output:
65W = 10255 lm
98W = 14970 lm
137W = 20070 lm

HIGH PERFORMANCE LED LOW BAY LUMINAIRES



SPECIFICATION

- Strong high pressure die-cast aluminium body finished full polyester powder coat silver (RAL9006)
- High impact UV stabilised polycarbonate cover rated IK10
- Long life silicone gaskets ensuring IP66 rating
- Smooth wipe clean surfaces, no dust traps
- Integral high efficiency driver
- Extremely efficient and long system life up to 100,000 hours
- Supplied with single-point, stainless steel welded link chain suspension kit
- Smart versions suitable for use at mounting heights up to 8m
- Wireless SmartScan versions remove the need for control cabling. Ideal for retro-fit solutions
- Separate non-maintained emergency versions available
- Fitted with 2m flying lead
- Fitted with 4000K LEDs

SmartScan Configurations



Find out more at www.thorlux.com/smartsan

COMBOSEAL

RANGE

	LED	CAT. No.	APPROX. kg	CIRCUIT
SMART	65W	CS 18476	6.6	D/SS
	98W	CS 18477	6.6	D/SS
	137W	CS 18478	6.6	D/SS
STANDARD	65W	CS 18479	6.5	L/A
	98W	CS 18480	6.5	L/A
	137W	CS 18481	6.5	L/A
EMERGENCY	8W	ECS 18484 ▲	6.4	
	8W	TCS 18484 ■	6.4	
	8W	WCS 18484 +	6.4	

CIRCUIT TYPE - suffix catalogue number with:

SMART D - Smart / SS - SmartScan

STANDARD L - non-dimming (LED) / A - dimming (DALI) e.g. **CS 18476SS** etc.

EMERGENCY VERSION: ▲ ECS - Emergency / ■ TCS - AutoTest / + WCS - SmartScan

LED CHARACTERISTICS

CRI	80+
COLOUR TEMPERATURE	4000K
RATED LIFE (HOURS)	100K - L70/B10
PROTECTION	LUX GUARD
DRIVER EFFICIENCY	90%
REPLACEABLE	YES
POWER FACTOR	>0.90
LL/CW	138.6

For LED characteristics explanation see
www.thorlux.com/led-guide



MAXIMUM AMBIENT OPERATING TEMPERATURES

LED	100,000 HOUR LIFE	50,000 HOUR LIFE
65W	50°C	60°C
98W	40°C	50°C
137W	25°C	35°C

Minimum operating ambient temperature - Standard & Smart versions: -40°C

EMERGENCY VERSION OPERATING TEMPERATURE RANGE

LED	MINIMUM	MAXIMUM
8W	5°C	40°C

Presence Detection Guide - www.thorlux.com/files/presence-detection.pdf

COMBOSEAL PLUS



SMART VERSIONS UP TO

18m

UP TO
44,000
LUMENS

DIMENSIONS

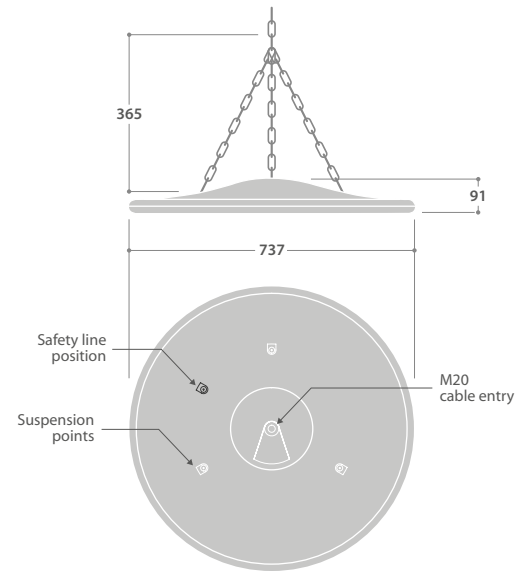

ACCESSORIES

DESCRIPTION	CAT. No.
Surface mount bracket	CS 18574

PHOTOMETRIC GUIDE

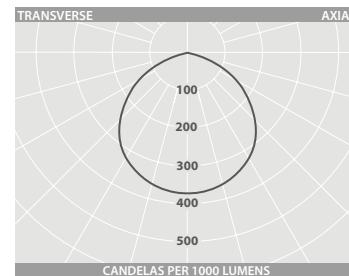

BROAD DISTRIBUTION

Luminaire Lumen Output:
171W = 25490 lm
251W = 35505 lm
326W = 43725 lm

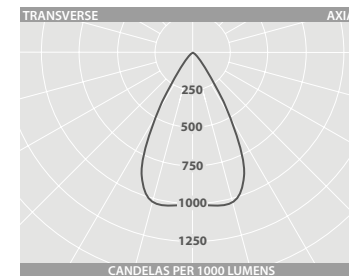

NARROW DISTRIBUTION

Luminaire Lumen Output:
171W = 25925 lm
251W = 36110 lm
326W = 44470 lm

HIGH PERFORMANCE LED HIGH BAY LUMINAIRES



SPECIFICATION

- Strong high pressure die-cast aluminium body finished full polyester powder coat silver (RAL9006)
- Clear flat toughened/safety glass cover
- Long life silicone gaskets ensuring IP66 rating
- Smooth wipe clean surfaces, no dust traps
- Integral high efficiency drivers
- Extremely efficient and long system life up to 100,000 hours
- Supplied with single-point, stainless steel welded link chain suspension kit
- Smart versions suitable for use at mounting heights up to 18m
- Wireless SmartScan versions remove the need for control cabling. Ideal for retro-fit solutions
- Fitted with 2m flying lead
- Fitted with 4000K LEDs

SmartScan Configurations



Find out more at www.thorlux.com/smartscan

COMBOSEAL PLUS



RANGE

	LED	BROAD DISTRIBUTION	NARROW DISTRIBUTION	APPROX. kg	CIRCUIT
SMART	Normal Ambient Versions				
	171W	CS 18550	CS 18556	16.2	D/SS
	251W	CS 18551	CS 18557	16.2	D/SS
	326W	CS 18552	CS 18558	16.2	D/SS
	High Ambient Versions				
	171W	CS 18553	CS 18559	17.2	D/SS
251W	CS 18554	CS 18560	17.2	D/SS	
326W	CS 18555	CS 18561	17.2	D/SS	
STANDARD	Normal Ambient Versions				
	171W	CS 18562	CS 18568	16.0	L/A
	251W	CS 18563	CS 18569	16.0	L/A
	326W	CS 18564	CS 18570	16.0	L/A
	High Ambient Versions				
	171W	CS 18565	CS 18571	17.0	L/A
251W	CS 18566	CS 18572	17.0	L/A	
326W	CS 18567	CS 18573	17.0	L/A	

CIRCUIT TYPE - suffix catalogue number with:

SMART D - Smart / SS - SmartScan

STANDARD L - non-dimming (LED) / A - dimming (DALI) e.g. **CS 18550SS** etc.

NOTE: Acrylic cover version available to special order

LED CHARACTERISTICS

CRI	80+
COLOUR TEMPERATURE	4000K
RATED LIFE (HOURS)	100K - L70/B10
PROTECTION	LUX GUARD
DRIVER EFFICIENCY	>90%
REPLACEABLE	YES
POWER FACTOR	>0.90
LL/CW	136.4

For LED characteristics explanation see www.thorlux.com/led-guide

MAXIMUM AMBIENT OPERATING TEMPERATURES

LED	NORMAL AMBIENT VERSIONS (INCLUDING SMART)		HIGH AMBIENT VERSIONS (INCLUDING SMART)	
	100,000 HOUR LIFE	50,000 HOUR LIFE	100,000 HOUR LIFE	50,000 HOUR LIFE
171W	40°C	50°C	55°C	65°C
251W	30°C	40°C	45°C	55°C
326W	25°C	35°C	40°C	50°C

Minimum operating ambient temperature - Standard & Smart versions: -40°C

Presence Detection Guide - www.thorlux.com/files/presence-detection.pdf



Designers, manufacturers and suppliers
of professional lighting systems

INDUSTRIAL LUMINAIRES
COMMERCIAL LUMINAIRES
FLOODLIGHTING LUMINAIRES
ARCHITECTURAL LUMINAIRES
HEALTHCARE LUMINAIRES
HAZARDOUS AREA LUMINAIRES
RETAIL AND DISPLAY LUMINAIRES
CONTROLS AND SYSTEMS

A DIVISION OF F.W. THORPE PLC

Thorlux Carbon Offsetting Project:
www.thorlux.com/trees

The information given in this catalogue is typical and must not be interpreted as a guarantee of individual product performance and/or characteristics. We reserve the right to alter specifications and designs without prior notice.

Thorlux Lighting
Merse Road
North Moons Moat
Redditch
Worcestershire
B98 9HH
England

T +44 (0)1527 583200
F +44 (0)1527 584177
E thorlux@thorlux.co.uk
W www.thorlux.com

Direct UK Sales Line: 01527 583222

Thorlux Lighting Ireland
Unit G6
Riverview Business Park
Nangor Road
Gallanstown
Dublin 12
Ireland

T +353 (0)1 460 4608
F +353 (0)1 460 4609
E thorlux@thorlux.ie
W www.thorlux.ie

Thorlux Lighting Deutschland
Ernst Gnoß Strasse 7
40219 Düsseldorf
Deutschland

T +49 (0)211 695 603-10
F +49 (0)211 695 603-11
E thorlux@thorlux.de
W www.thorlux.de

Thorlux Lighting Australasia Pty Ltd.
31 Cross Street
Brookvale
Sydney
NSW 2100
Australia

T 1300 04 32 32
T +61 (0)2 9907 1261
E thorlux@thorlux.com.au
W www.thorlux.com.au

Registered No. ABN 139 400 507

Thorlux Lighting LLC
Office 334
European Business Centre
Green Community
Dubai Investment Park 1
PO Box 33484
Dubai
United Arab Emirates

T +971 (0)2 656 5842
F +971 (0)2 622 4149
E sales@thorlux.ae
W www.thorlux.ae

